

REVERSIBLE BOX TOTE

PATTERNS FOR THE MODERN SEWER & KNITTER



**FREE
PATTERN
DOWNLOAD!**

VERY SHANNON





VERYSHANNON.COM

HOW WILL YOU MAKE YOUR REVERSIBLE BOX TOTE TODAY?

The Reversible Box Tote bag is perfect for customizing! Try adding color blocking, mixing fabrics and prints for personalized and stylish projects! You could even swap out the interfacing for quilt batting and quilt the Outer Bag before sewing the lining to it!

Want zippered pockets? Snaps? Velcro? Go for it! Have some fun!

OPTION NOTES

SIZE, FABRIC REQUIREMENTS, SUPPLIES & TOOLS

FINISHED MEASUREMENTS

The Reversible Box Tote Pattern was designed to fit either your Outer or Inner fabric out of a ½ yard of fabric nicely or both your outer and your lining fabric out of 1 yard.

Finished Reversible Box Tote measures:

8"H (14"H including the handle) x 17"W

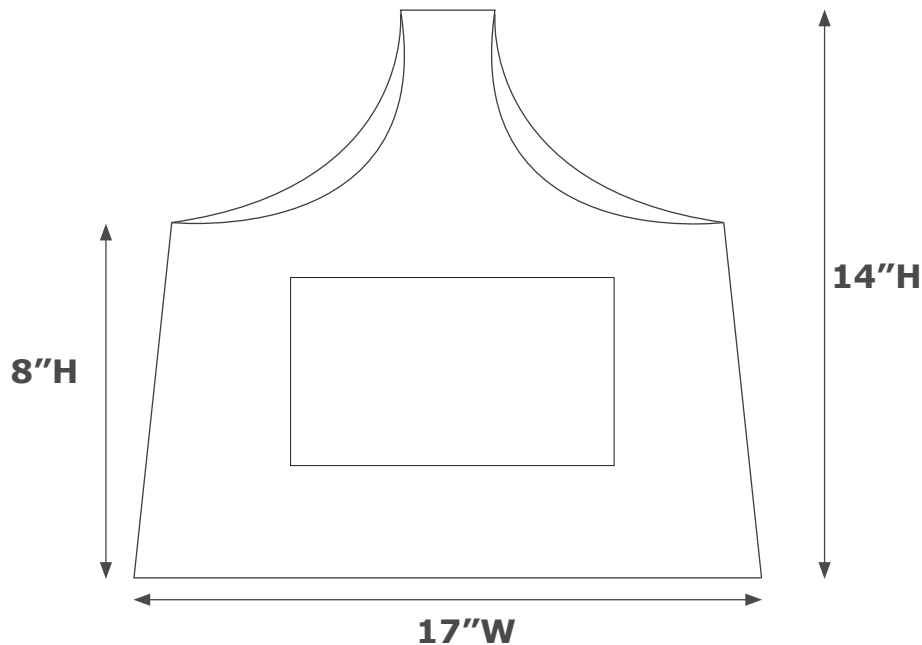

FABRIC REQUIREMENTS

The fabric requirements listed below vary based on your fabric selection and the placement of your fabric. Please note that the requirements given are for non-directional prints only.

Directional prints may require more fabric. Please plan accordingly when purchasing fabric. All requirements are based on 45"/115cm width fabric.

FABRIC REQUIREMENTS FOR REVERSIBLE BOX TOTE	
Reversible Box Tote Pattern Piece	35"W x 18"H (or 35"W x 36"H for both outer and lining fabric)
Pocket Pattern Piece	38"W x 6"H (or 9.5"W x 24"H)
Interfacing for Tote	35"W x 18"H

TOOLS

Removable fabric marker or tailor's chalk.

SUPPLIES

Rotary Cutter w/mat
Scissors
Pins
Firm Fusible Interfacing - we used and love **Pellon 80g Decor-Bond** for this project!
Co-ordinating Thread

PATTERN PIECES & CUTTING INSTRUCTIONS

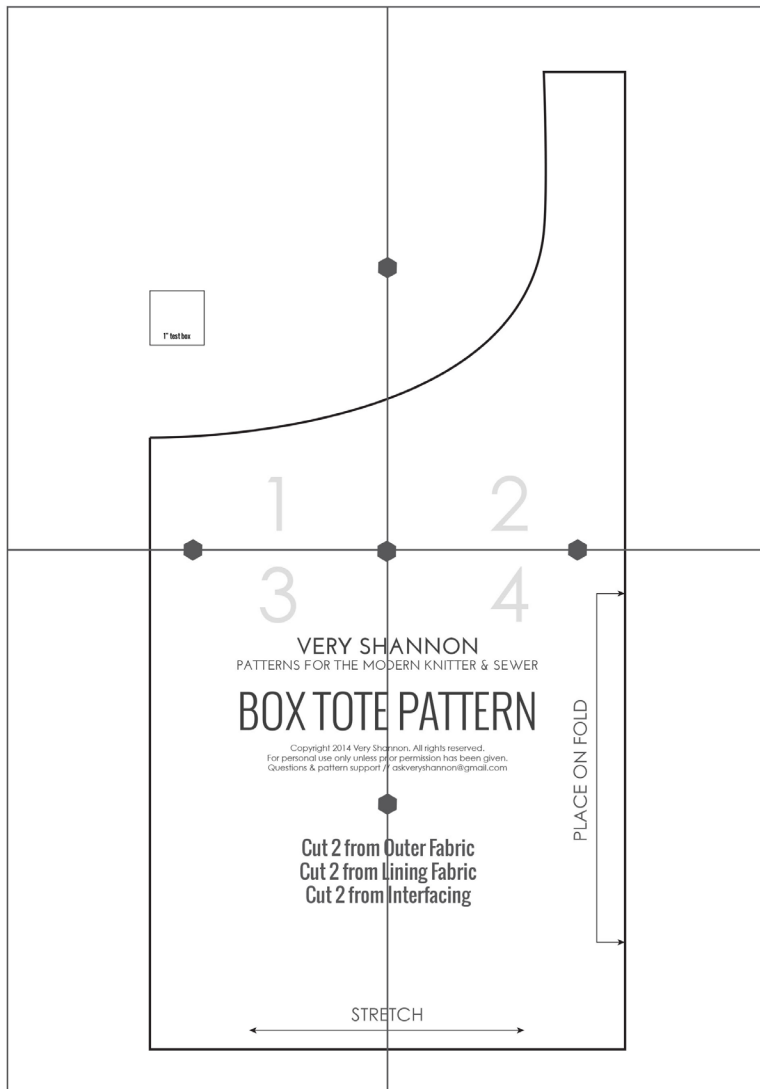

Print out your Box Tote & Pocket pattern pieces found on **Pages 12 to 16** using our Printing Instructions found on **Page 6**.

Cut out from your desired fabric the following for your Tote:

- 2 - Outer Bag Fabric
- 2 - Lining Bag Fabric
- 2 - Interfacing

Cut out from your desired fabric the following for your Pockets:

- 4 - Pocket Pieces (2 for Outer/2 for Lining)
- Optional for a sturdy pocket:
 - 2 - Interfacing

PATTERN NOTES

BEFORE YOU BEGIN

PRINTING INSTRUCTIONS

Page size is 8.5" x 11". Pattern can be printed on both 8.5" x 11" paper and size A4.

Confirm when printing your pattern pieces that your printer is set to "actual size" and/or you set your page scaling to "none". Be sure not to select "shrink to fit" or any other page scaling as this will result in your pattern pieces being the incorrect size and your garment may not fit.

1. Seam allowances are already included on the pattern pieces.
2. Before printing out your entire pattern print out **Page 12** and double check your 1" test box. This is an important step that will save you from printing out the whole pattern in the wrong size. If the 1" test box is accurate after printing you are safe to print out all of your pattern pieces.

HELPFUL TIP

To be environmentally friendly print only your pattern pages and use a tablet/cellphone/ computer to read your pattern instructions.

*Pattern pages ONLY can be found from **Pages 12 to 16**. Instructions can be found on **Pages 1 - 11**.*

TAPING INSTRUCTIONS

1. Print out all pattern pieces following the instructions given in Printing Instructions above.
2. Trim one horizontal and one vertical edge of each pattern page before taping. It's easiest to use a paper cutter and lay the pages atop of each other while cutting evenly but this can be done by hand as well or by using a rotary cutter just for paper. I recommend reading **this great tutorial** from Crafterhours on a fast & easy way to assemble PDF pattern pieces.
3. Simply match up each page with it's coordinating page using our hexagon to align the pages. Tape or glue (using a glue-stick) pages together.
4. After all your pages are joined together cut out or trace your pattern pieces.

TERMS OF USE



This pattern is for personal use only. The purchaser may create sewn items for personal use or for charity. For commercial use, resale or for classes please contact us directly at **askveryshannon@gmail.com**

Permission to Sell Limited Licenses are available and information/pricing can be found at **www.veryshannon.com/patterns** or by emailing **askveryshannon@gmail.com**. We are happy to promote our licensed sellers. Our licensed sellers page can be found here: **www.veryshannon.com/licensedsellers**.

Any reproduction of this pattern in part or in whole is strictly prohibited. This pattern & its instructions are protected by copyright law. Please honor my copyright.

BEFORE YOU BEGIN

TIPS FOR SEWING

1. Read all instructions carefully before sewing.
2. Always wash/dry/press your fabrics before sewing with them unless fabric care states otherwise.
3. Follow the pattern **Cutting Instructions** to find out how many pieces to cut.
4. Trace or cut your pattern along your selected size taking care to mark all notches & other pattern markings onto your fabric with a removable fabric marker or tailor's chalk.
5. Seam allowances are included in the pattern and are ¼" unless otherwise stated.
6. Start and finish all seams with a backstitch unless otherwise stated.
7. Always press your seams as you work through the pattern.
8. Clip seam allowances where necessary. Clip corners of seam allowance to reduce bulk. Doing so enables your curves to lay nicely & flat.
9. Right side is depicted by white.  Wrong side is depicted by grey. 

GLOSSARY

1. **TOPSTITCH:** A straight stitch that is sewn ⅛"/.32cm along the right edge of a seam.
2. **FINISH THE SEAM ALLOWANCES:** You may choose to use a serger, finish your seams by running a zigzag stitch over the raw edge of your seam allowance or by simply sewing a straight stitch ¼"/.64cm from your raw edge then trim your seam allowance with pinking shears.
3. **BACKSTITCH:** Sew in reverse for a few stitches at the beginning and end of your seam. This helps to prevent your stitches from coming unsewn.
4. **EDGESTITCH:** A row of stitching that appears on the very edge of a garment, normally ⅛"/.32cm or less.
5. **RS AND WS:** RS is the right side of your fabric and WS is the wrong side of your fabric (the inside of your garment would be the WS of your fabric).
6. **NOTCHING:** With your scissors carefully clip into and along your seam allowance.

SOCIAL MEDIA

For more patterns & projects, please visit veryshannon.com. To stay up-to-date with new releases, events & projects please sign up for our FREE newsletter. Click [HERE](#) to join.

We love seeing your fabric choices, projects in progress and finished projects! Tag your Reversible Box Tote Bags online using the hashtag [#RBTote](#)! And don't forget to upload your project pics to our Flickr Group [HERE](#).

You can find Very Shannon on [facebook](#), [instagram](#), [pinterest](#), [twitter](#), [bloglovin](#) & [google +](#).

SEWING INSTRUCTIONS

HELPFUL TIP: All seam allowances are $\frac{1}{4}$ " unless otherwise stated.

STEP ONE: PREPPING YOUR FABRIC

Cut out your Outer & Lining Bag Pieces and your interfacing.

Iron as per the manufacturer's instruction the interfacing to your Outer Bag Pieces ONLY.

**Option: If you would like stiffer pockets feel free to cut and fuse interfacing to 1 side of your pocket piece as well.*

STEP TWO: ASSEMBLING YOUR POCKETS

With RS facing each other, sew along all 4 sides of your pocket taking care to leave a 2" opening unsewn along the top edge of your pocket to pull your pocket right side out through.

Trim your corners neatly, taking care not to cut through your stitching, to allow for a nice corner when finished.

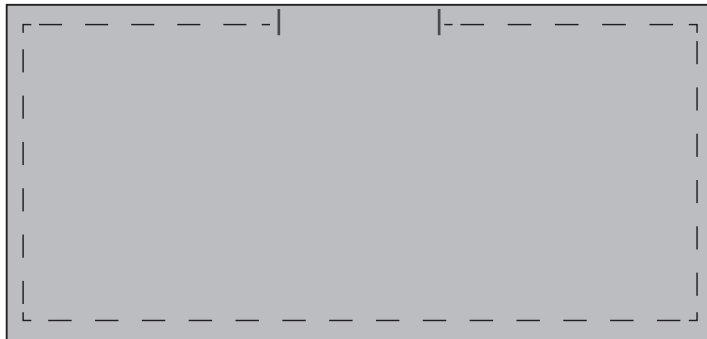

Turn your pocket RS out. Iron pocket carefully while also turning under a $\frac{1}{4}$ " seam allowance along the top portion of the pocket that was unsewn. Pin this section closed.

Topstitch along the upper edge of your pocket enclosing the unsewn portion.

Repeat the above steps for your other pocket. You will now have a pocket for your Outer Bag and one for your Inner Bag.



STEP THREE: ATTACHING YOUR POCKETS

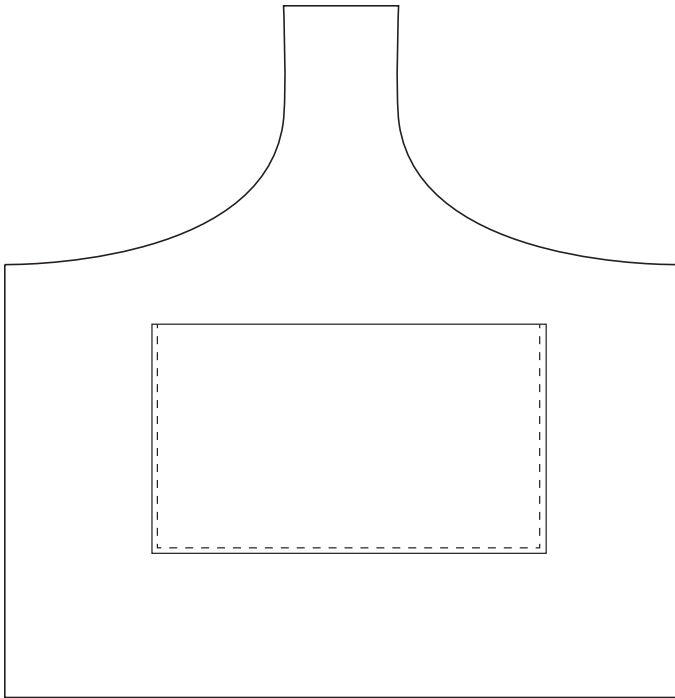

Lay one of your Outer Bag Pieces right side facing up. Measure down 8.5" down from the top of the strap. Mark this with your removable fabric marker or chalk.

Now mark the center of your bag at the same distance down from the top of the strap.

Next find the center of your Pocket Piece. Pin your pocket down onto your bag carefully matching up your center points and aligning the top of your pocket with the 8.5" distance down from the top of your strap.

Topstitch your pocket down along 3 sides of your pocket, leaving the top portion unsewn to form your pocket taking care to backstitch well at the start and finish of sewing to ensure a strong pocket.

Repeat the above steps for your other Pocket Piece this time attaching it to one of your Inner Bag Pieces.

STEP FOUR: ASSEMBLING YOUR BAG

Place your Outer Bag Pieces RS facing each other. Pin and sew along your side and bottom edges.

Next pin and sew your top strap edges together. Press your seam allowances open.

Repeat these steps for your Lining Bag Pieces.

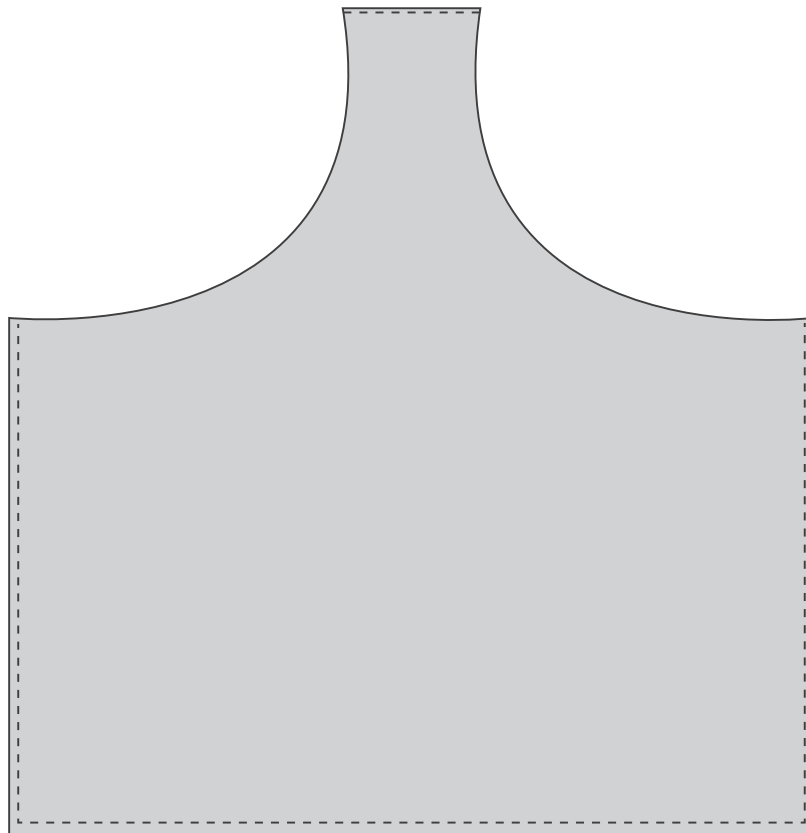

STEP FIVE: MAKING YOUR BOX CORNERS

With your Outer Bag still inside out, match your side seam with your bottom seam to create a point. Pinch and flatten the corner so your seam allowance is now centered and right in front of you. Double check your seam allowances match for a nice finish. Pinch and flatten the corner out. Lay it flat.

Measure out and mark 2" away from the corner (or point). Draw a line from edge to edge. Pin flat.

Sew along the line you just drew.

Repeat for your other corner. Turn bag right side out and make sure you are happy with the look. If so, trim your corners down to $\frac{1}{4}$ " seam allowance.

Repeat for your Lining Bag. Both your Outer Bag and your Lining Bag will now have box corners.

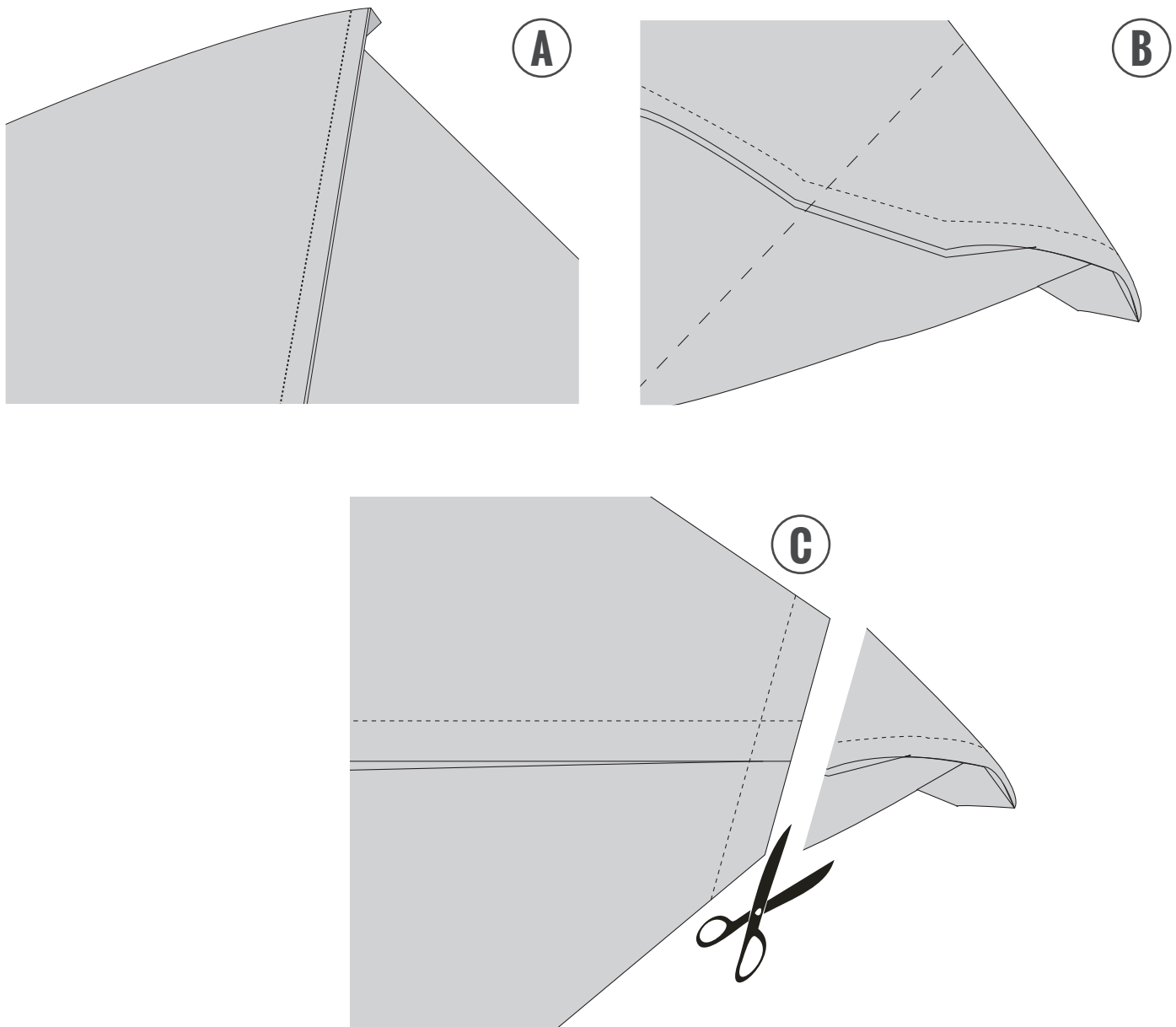

STEP SIX: FINISHING YOUR BAG

Turn your Lining Bag inside out and your Outer Bag right side out. Fold and press a ¼" hem around each handle and top of your bags.

Place your Lining Bag inside your Outer Bag. Match the center seam of your handles together and pin in place.

Now carefully match up the top of the bags side seam allowances together and pin. Now pin carefully around the rest of the tops of the bags and sides of your handle, making sure to keep the bags even and aligned.

Topstitch along your top openings close to the edge carefully and neatly.

HELPFUL TIP

It helps to sew this step with your Lining Bag right side facing up (you will see this side when your sewing foot is down) and your Outer Bag right side facing down. Take note that your bobbin thread will be the color that will show on your Outer Bag.

Press your bags neatly if any creasing of your interfacing has occurred.

You're done! You did a great job! Enjoy your new tote!

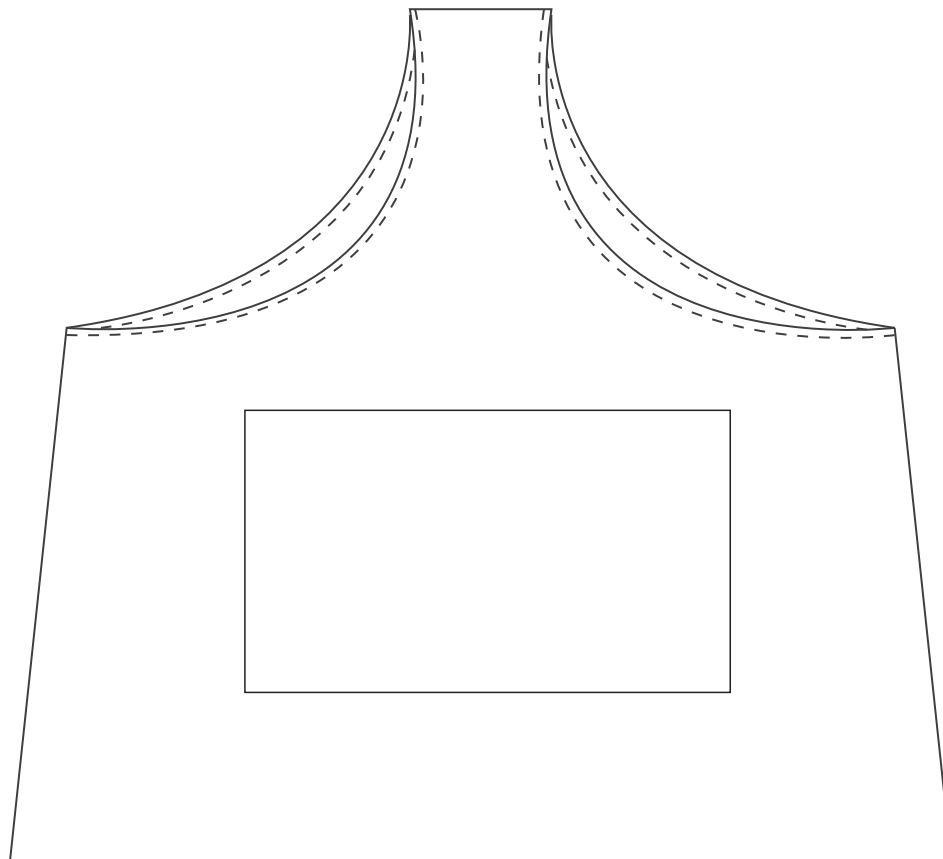

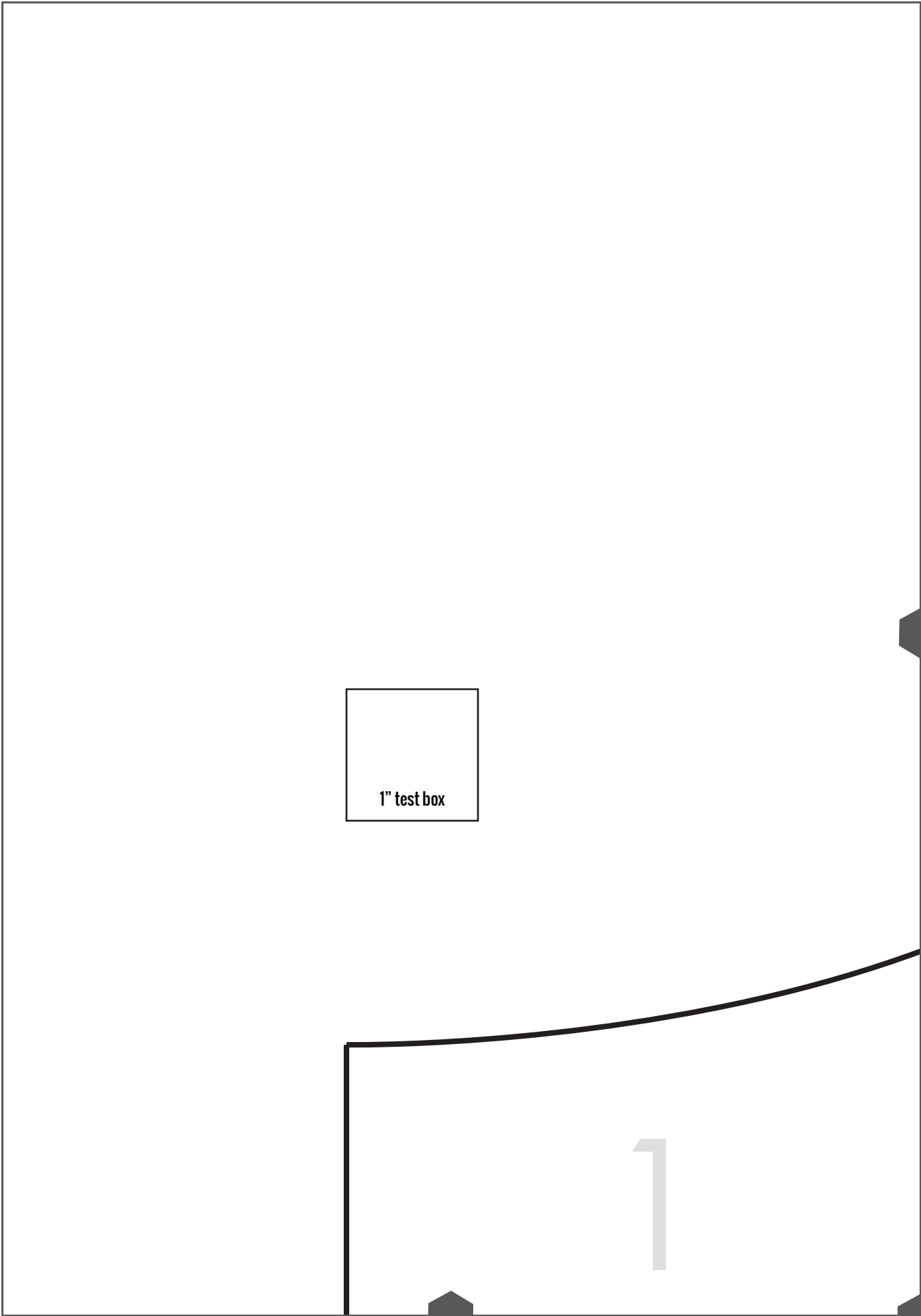

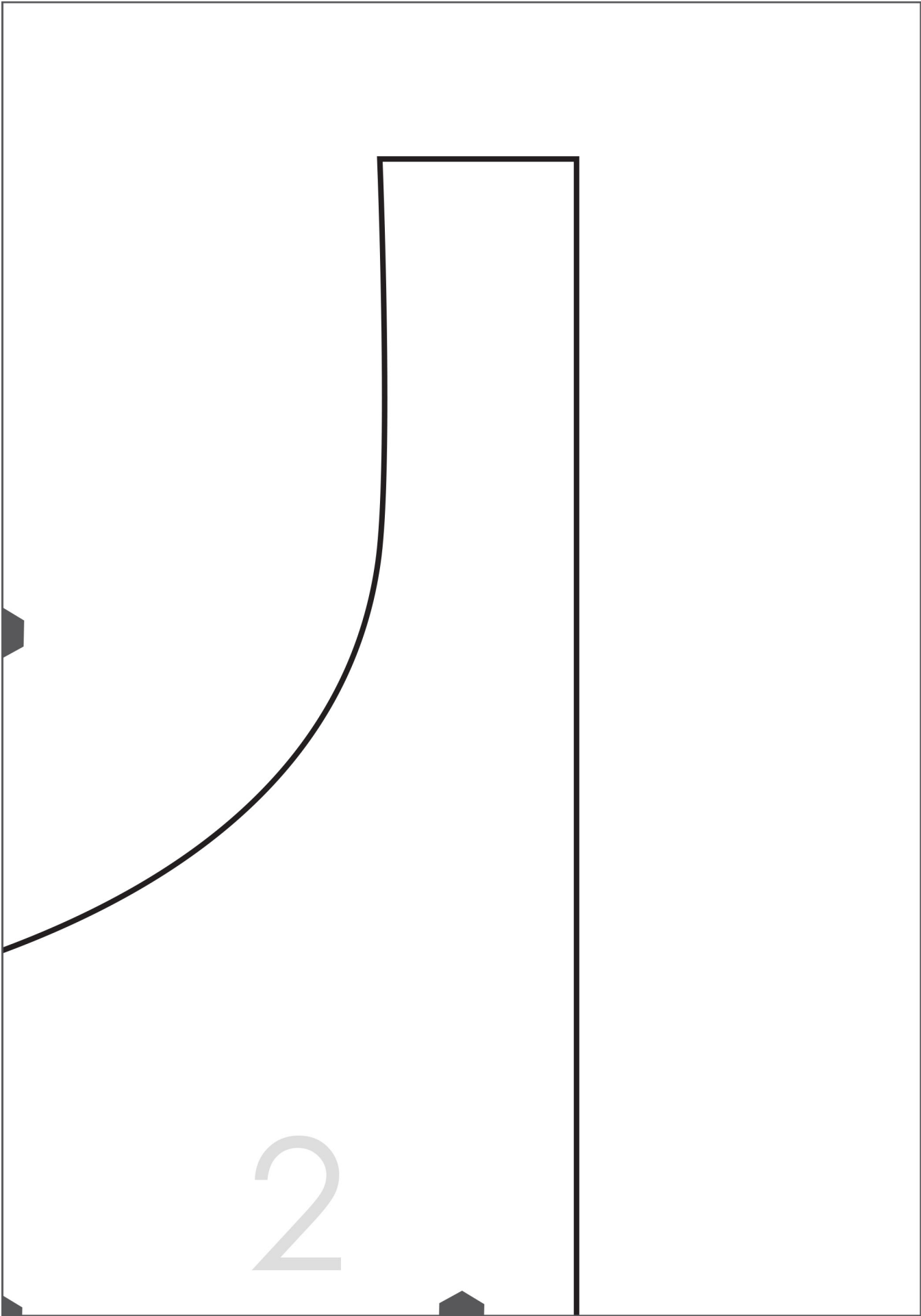

3

VERY SH
PATTERNS FOR THE MO

BOX TOTE

Copyright 2014 Very Sho
For personal use only unless pr
Questions & pattern support /

Cut 2 from C
Cut 2 from L
Cut 2 from

STRE



4

ANNON
MODERN KNITTER & SEWER

PATTERN

Shannon. All rights reserved.
No permission has been given.
/askveryshannon@gmail.com

Outer Fabric
Lining Fabric
Interfacing

PLACE ON FOLD

TCH

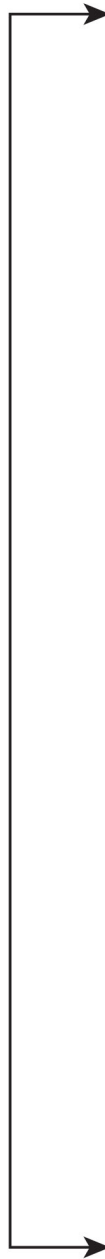



VERY SHANNON
PATTERNS FOR THE MODERN KNITTER & SEWER

BOXTOTE POCKET PATTERN

CUT 4 FROM POCKET FABRIC
***OPTIONAL: CUT 2 FROM INTERFACING**

STRETCH 